



Item No. \_\_\_\_\_

# C118

## Batch Ice Cream Freezer



### Features

Serve homemade, low and medium overrun gourmet ice cream, gelato, sorbet, Italian ice and slush. Mix and liquid flavorings may be poured into the convenient fill chute on the door. Fruits, candies and nuts can be folded in as product is being drawn into your container. Manufactured in Italy by Frigomat to ensure European equipment quality and technology to serve gelato or low to medium overrun super-premium ice cream.

**Freezing Cylinder**  
One, 12.4 quart (11.7 liter).

**Totally Automatic**  
Equipment is designed with quality features for the inexperienced operator. Microprocessor monitors the refrigeration, mechanical and electrical systems, which allows totally automatic operation to produce the best possible consistency, batch after batch.

**Semi-Automatic Setting**  
For the experienced ice cream maker, a semiautomatic setting may be selected to allow the operator to personalize the product according to a specific recipe. This setting is recommended for fruit sorbet.

**Electronic Consistency Control**  
Automatically senses product viscosity to control the refrigeration system for perfect ice cream quality, batch after batch. Operator may override automatic controls at the touch of a button.

**Variable Batch Size**  
Control automatically manages the freezing cycle in relation to the pre-charge of mix within a wide range of values.

**Two-Speed Beater**  
Quickly ejects ice cream when the batch is finished, leaving very little residue in the freezing cylinder.

**Rinse Faucet**  
Retractable hose allows spray nozzle to fit right into the front panel, conveniently located next to the dispensing door.



Standard 6



SA2650



Selected 50 Hz. Models

Taylor Freezer Sales Company  
Virginia 800-768-6945  
Phone 757.545.7900 Fax 757.545.7908  
www.taylorfreezer.com  
e-mail: cphelps@taylorfreezer.com

North Carolina 800.768.6945  
Fax 704.319.2464  
www.taylorfreezer.com  
e-mail: jroot@taylorfreezer.com

# C118 Batch Ice Cream Freezer

34-13/16 (884) (WATER COOLED)

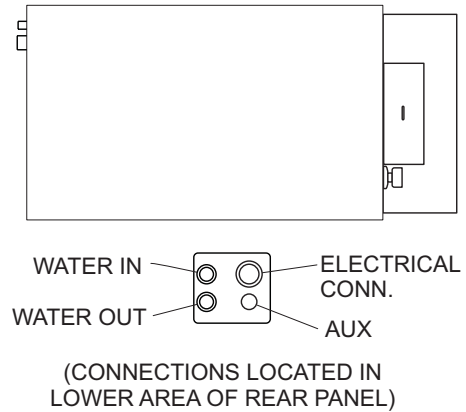
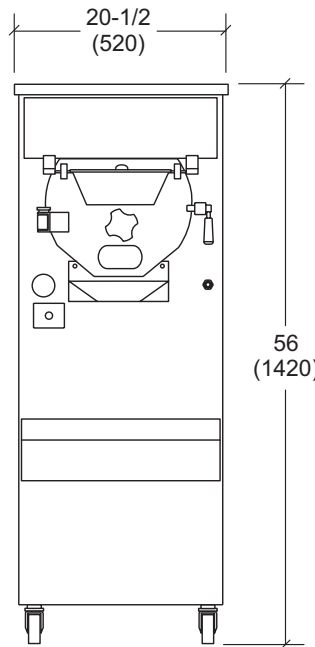
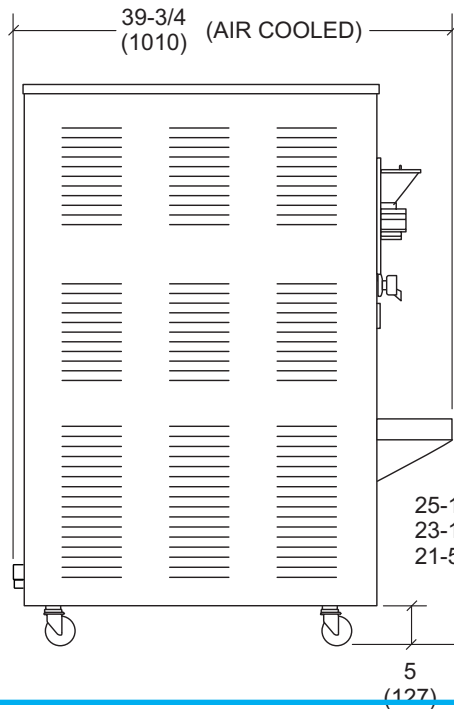

NOTE: FIGURES IN PARENTHESES INDICATE MILLIMETERS.

Weights	lbs.	kgs.
Air Cooled - Net	606	275
Air Cooled - Crated	728	330
Water Cooled - Net	540	245
Water Cooled - Crated	661	300
Shipping Volume	cu. ft.	cu. m.
Air Cooled	25.4	0.72
Water Cooled	22.2	0.63

Dimensions	in.	mm.
Width	20-1/2	520
Water Cooled Depth	33-11/16	855
Air Cooled Depth	38-5/8	980
Height	56	1420
Floor Clearance: 5" (127 mm) mounted on standard casters		

Electrical	Maximum Fuse Size	Minimum Circuit Ampacity	Poles (P) Wires (W)
208-230/60/3 Air	35	28	3P 4W
208-230/60/3 Water	35	28	3P 4W

This unit may be manufactured in other electrical and cooling characteristics. Refer to the local Taylor Distributor for availability. (For exact electrical information, always refer to the data label of the unit.)

## Bidding Specs

Electrical: Volt \_\_\_\_\_ Hz \_\_\_\_\_ ph \_\_\_\_\_  
Neutral:  Yes  No Cooling:  Air  Water  NA

Options: \_\_\_\_\_

## Specifications

### Electrical

One dedicated electrical connection is required. See the Electrical chart for the proper electrical requirements. Manufactured to be permanently connected. Consult your local Taylor distributor for cord & receptacle specifications as local codes allow.

### Beater Motor

One, two speed beater motor. 2.5 HP at low speed, 4.0 HP at high speed.

### Refrigeration System

One, approximately 16,500 BTU/hr. R404A. (BTUs may vary depending on compressor used.)

### Air Cooled

Minimum 6" (152 mm) on both sides and 12" (305 mm) at rear. Minimum air clearances must be met to assure adequate air flow for optimum performance..

### Water Cooled

Water inlet and drain connections on back panel 1/2" MPT.

## Options

- Two flight beater for lower overrun

Continuing research results in steady improvements; therefore, these specifications are subject to change without notice.



**Taylor Company,**  
A Division of Carrier Commercial Refrigeration, Inc.  
Rockton, Illinois 61072  
815-624-8333 800-255-0626 Fax 815-624-8000  
www.taylor-company.com

Printed in U.S.A.

058463-ADV 12/04