

CARPIGIANI

LB-100B

Batch Freezer Counter Model



The Perfect Solution for Chefs and Small Operations!

This compact batch freezer offers the same quality and durability of our larger models, while fitting on your counter. In a matter of minutes, you can create the finest gelato, ice cream, sorbets, and much more! Chefs, fine restaurants, bakeries, and coffee shops across the nation choose Carpigiani, maker of the finest batch freezers in the world.

Features Include:

- Electronic consistency control offers semi-automatic operation
- Heavy duty drive system results in a firmer product and longer machine life
- Cylinder design provides faster production and smoother product
- Auger design provides maximized extraction, minimizing flavor overlap
- Adjustable timer alerts you when product is ready
- Cleans and sanitizes in minutes

CARPIGIANI

800-648-4389 • 336-661-9893 • Fax: 336-661-9895 • P.O. Box 4069 • Winston-Salem, NC 27115

www.carpigiani-usa.com • info@carpigiani-usa.com



Carpigiani is also the world's leading provider of hands-on frozen dessert instruction.

Find out more at www.frozendessertuniversity.com

SPECIFICATIONS

MODEL LB-100B

Single speed counter model for low volume requirements.

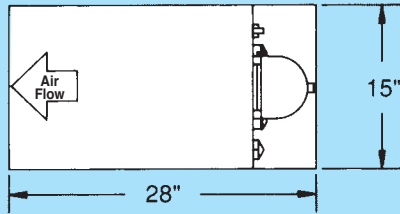

Plan View

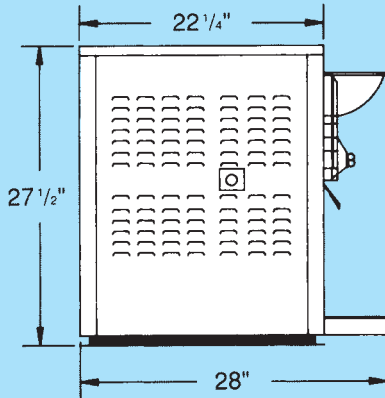

Side View

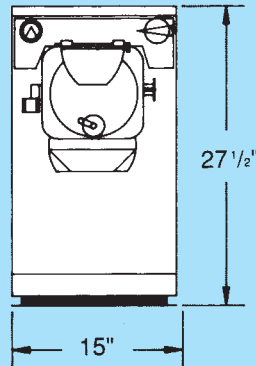

Front View

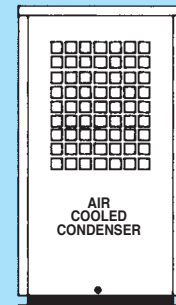

Rear View

Model LB-100B Description:

Production Per Hour _____ 4-1/2 Gal.
 Cylinder Capacity with Beater _____ 4 Qts.
 Cylinder Length _____ 6-1/8 inches
 Cylinder Diameter _____ 7 inches
 Cylinder Refrigeration
 Control System _____ Electronic H.O.M.
 Evaporator Type _____ Helicoidal Path
 Refrigerant Type _____ R-404A
 Beater Construction _____ Unibody - DELRIN Blade
 Beater Motor _____ 3/4 H.P.
 Compressor Motor _____ 1.0 H.P.
 Condenser (Cooling System) _____ Air Only
 Water Connections _____ None
 Frame Type _____ Counter Model
 Frame Construction _____ Welded Steel
 Outer Panels _____ Stainless Steel
 Width _____ 15 inches
 Depth _____ 28 inches

Depth without Drip Tray _____ 22-1/4 inches
 Height _____ 27-1/2 inches
 Net Weight (w/o accessories) _____ 210 Lbs.
 Gross Weight (w/o accessories) _____ 253 Lbs.

Electrical Requirements

Voltage Single Phase, 60 Cycle _____ 208/230 V
 Fuse/Breaker Size _____ 20 Amp Max.

A small, compact, professional, quality constructed counter model Batch Freezer. Carpigiani's advanced technology now makes it possible to produce delicious desserts such as Italian Gelato, Sorbetto (Fruit Flavored Water Ice), and gourmet quality ice cream on your counter top. All you need is 2-1/2 sq. ft. of space. Simply pour your mix and flavor into the cylinder and switch on. It takes only minutes to complete a batch.

Carpigiani-USA manufactures a complete line of frozen dessert production equipment: Batch Freezers, Soft Serve Freezers, Yogurt Freezers, Slush Freezers, Milk Shake Machines, Granita Machines, Whipped Topping Dispensers, Frozen Custard Freezers, Specialty and Mix Processing Equipment, Display Cabinets...

Something for everyone!

Distributed by:

All technical data, pictures, and drawings contained in this document are not binding on the manufacturer, nor can the manufacturer be held liable for any modification of the machine, in part or in whole.